

Grain Boundary Faceting Phase Transition and Thermal Grooving in Cu

B.B. Straumal¹, S.A. Polyakov^{1,2}, E. Bischoff², E. J. Mittemeijer² and W. Gust²

¹ Institute of Solid State Physics, Russian Academy of Sciences, Chernogolovka,
Moscow District, 142432 Russia

² Max Planck Institute for Metals Research and Institute of Physical Metallurgy, Heisenbergstr.3,
70569 Stuttgart, Germany

Keywords: grain boundaries, faceting, roughening, Cu, $\Sigma 3$, $\Sigma 9$, phase diagrams

Abstract. Faceting is a well documented phenomenon known both for surfaces and interfaces, particularly, grain boundaries (GBs). Faceting can be considered as a phase transition when the original surface or GB dissociates onto flat segments whose energy is less than that of the original surface or GB. For the investigation of GB faceting a cylindrical Cu bicrystal with an island grain was grown by the Bridgman technique. Grain 1 in this bicrystal is completely surrounded by grain 2. The dissociation $\Sigma 9 \Sigma 3 + \Sigma 3$ proceeds during the growth of the bicrystal. The twins appear instead of $\{111\}_1/\{115\}_2$ or $(110)_{\Sigma 9\text{CSL}}$ facet. GB faceting was studied at 1293 K, 1073 K, and 873 K. The profiles of the GB thermal groove were analysed by atomic force microscopy. Wulff-Herring plots and GB phase diagrams have been constructed for the $\Sigma 3$, $\Sigma 9$ and $\Sigma 9+\Sigma 3$ GBs. With increasing temperature the facets with low-density CSL-planes disappear in the GB shape. GB roughening phase transition can be responsible for this phenomenon.

Introduction

Faceting is a well documented phenomenon known both for surfaces and interfaces, particularly, grain boundaries (GBs) [1–4]. Faceting can be considered as a phase transition when the original surface or GB dissociates into flat segments whose energy is less than that of the original surface or GB. GB faceting proceeds only close to the so-called coincidence misorientations. In this case the lattices of both grains form the coincidence site lattice (CSL) characterized by the parameter Σ (reverse density of coincidence sites). In most cases the GB facets lie in the CSL planes with high density of coincidence sites. In [5] it has been shown that the GBs possess special structure and properties in limited areas of temperature T and misorientation θ close to a coincidence misorientation θ_{Σ} . In other words, by increasing $\Delta\theta = |\theta - \theta_{\Sigma}|$ and T the phase transition "special GB – general GB" proceeds and the GB loses its special structure and properties [6]. The higher Σ , the lower the temperature and $\Delta\theta$ at which a GB loses its special structure and properties. This is due to the fact that for the CSLs with low Σ the depth of the energetic profile for the dense packed CSL planes is higher than that of high- Σ CSLs.

Therefore, due to the temperature disordering the energetically favourable GB positions disappear at lower T for GBs with higher Σ [7]. Similar phenomena can be expected also for GB facets lying in different CSL planes. We can expect that at high temperature only the facets with highest density of coincidence sites appear, and with decreasing temperature the number of existing facets will gradually increase, including the facets with less and less dense packed coincidence sites and shallower energetic minima. The best objects for the search of this phenomenon would be the CSLs where the different CSL planes do not have very different density of coincidence sites. CSL with $\Sigma = 9$ fulfils this condition [8, 9]. In fact, the results of computer modelling for CSL with $\Sigma = 9$ show that the GB lying along different CSL planes possess very similar energy [9].

Experimental

For the investigation of GB faceting, a cylindrical Cu bicrystal with an island grain was grown by the of Bridgman technique from Cu of 99.999 wt. % purity. The grain 1 in this bicrystal is completely surrounded by the grain 2 forming the $\Sigma 9$ $\langle 110 \rangle$ tilt GB. The $\langle 110 \rangle$ axes in both grains are parallel to the growth axis. Therefore, the $\Sigma 9$ $\langle 110 \rangle$ tilt GB in the sample contains all crystallographically possible inclinations. 2.5 mm thick platelets were cut from the grown bicrystal perpendicularly to the growth axis. The platelets were ground with 4000 SiC paper and polished with 3 and 1 μm diamond paste. After that they were annealed in 80% Ar + 20% H_2 gas mixture at pressure of 2×10^4 Pa at different temperatures (1293 K, 48 h; 1073 K, 2374 h and 873 K, 2391 h). The annealed samples were then etched in the 50% HNO_3 aqueous solution. The GB shape and geometry of facets were analysed and photographed in polarized light in bright and dark field with the aid of an Zeiss Axiophot optical microscope.

The sample annealed at 1293 K was then carefully repolished and annealed 48 h once again in order to form GB thermal grooves. The profiles of the formed GB thermal groove were analysed with the aid of a Topometrix 2000 Explorer atomic force microscope (AFM) operating in the contact mode. The typical field analyzed with the aid of AFM had a dimension $50 \times 50 \mu\text{m}$ containing 500×500 pixels. For the analysis, each 10 neighbouring profiles were used to obtain a mean profile. The finite radius of the AFM needle does not allow to measure correctly the profile close to the tip of the groove. Therefore, the approximated "left" and "right" halves of the groove profile were extrapolated down to the intersection point. This procedure allows one to determine the coordinates of the "true" groove tip which is positioned lower than the tip observed by the AFM. The polynomials of 4th order were used for the approximation of each half of the groove profile. The derivatives for both halves of the groove profile were determined in the intersection point. Their sum delivers the value of "true" $\cos 2\theta$. The ratio between GB energy σ_{GB} and surface energy σ_{sur} was calculated using the values of measured GB groove angles 2θ .

Results and Discussion

It is well documented in the literature that close to the $\{111\}/\{115\}$ inclination the $\Sigma 9$ GB is unstable against the dissociation reaction: $\Sigma 9 \rightarrow \Sigma 3 + \Sigma 3$. This dissociation proceeds also in our case. The twins appear during the growth of bicrystal instead of $\{111\}_1/\{115\}_2$ or $(110)_{\Sigma 9}\text{CSL}$ facets (the subscripts 1 and 2 correspond to the grains 1 and 2). The $\Sigma 3$ twins were not present in the seeds. This fact permitted us to study the faceting of both $\Sigma 3$ and $\Sigma 9$ GBs simultaneously in the same samples.

Table 1. The presence of different $\Sigma 3$ facets at different temperatures in Cu. Corresponding inclination angles θ for various CSL planes are also given. Minory facets are marked as (m).

Facet	(100)	(010)	9R	(110)	(210)	(130)	Reference
θ , deg	0	90	82	55	71	25	
T/T_m							
0.95	+	-	+	-	+(m)	+(m)	This work
0.87	+	-	+	-			[10–14]
0.87	+	-	+	-			[10, 15]
0.79	+	-	+	-	-	+(m)	This work
0.64	+	-	+	+			This work
0.64	+	+	-	-			[16]
0.36	+	+	-	-			[17]
0	+	+	-	-			[9]

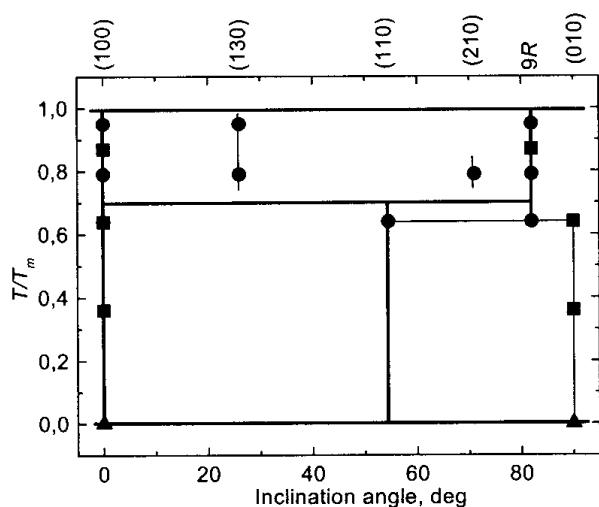

Fig. 1 Phase diagram for the various $\Sigma 3$ facets. T_m is the melting temperature. The inclinations of $\Sigma 3$ CSL planes are shown at the top of the diagram. Circles denote the facets experimentally observed in this work at $0.95 T_m$ (1293 K), $0.79 T_m$ (1073 K) and $0.64 T_m$ (873 K). Squares denote the facets experimentally observed at $0.87 T_m$ [10–15, 23], at $0.64 T_m$ [16] and at $0.36 T_m$ [17]. Triangles denote the energetic minima obtained using computer modelling [19]. Thick lines denote the temperature ranges of the stability for the major GB facets obtained in this work. Thin lines denote the (1) minor

facets (130)_{CSL} and (210)_{CSL} observed in this work and (2) the range of existence for the (010)_{CSL} facet and low-temperature boundary for the 9R facet based on the comparison of our data with published observations of other authors [16, 17]. Horizontal lines denote the upper limits of stability for (110)_{CSL} and (010)_{CSL} facets.

In Table 1 the data on the $\Sigma 3$ facets present in our samples after annealing at 1293, 1073 and 873 K are collected together with the data available in the literature. The energy of symmetric $\Sigma 3$ twin ($\{111\}_1/\{111\}_2$ or (100) _{$\Sigma 3$ CSL} facet) is very low. The second close packed plane is $\{211\}_1/\{211\}_2$ or (010) _{$\Sigma 3$ CSL} facet, the so-called asymmetric twin. The angle between facets (100) _{$\Sigma 3$ CSL} and (010) _{$\Sigma 3$ CSL} is 90° . The presence of such facets are well documented for Al, Au, AuCu₃, and Ge [18–21]. The typical rectangular twin plates with (100) _{$\Sigma 3$ CSL} and (010) _{$\Sigma 3$ CSL} facets can be seen, for example in Au thin films [19]. However, the twin plates in Cu and Ag are not rectangular. The end facet forms an angle of 82° with the $\{111\}_1/\{111\}_2$ or (100) _{$\Sigma 3$ CSL} sides [11,22]. TEM studies revealed that this 82° facet has so-called 9R structure forming a plate of bcc GB phase in the fcc matrix [10, 23, 24]. Such (100) _{$\Sigma 3$ CSL} and 82° 9R facets on the $\Sigma 3$ twin plate are clearly seen also in our samples at 1293 K and 1073 K. Moreover, analysis of the literature shows that the 82° 9R facet appears in Cu only at high temperatures. At low temperatures the "normal" 90° (010) _{$\Sigma 3$ CSL} facets are present also in Cu (see Table 1). Therefore, the GB phase transition seems to occur close to $0.64 T_m$ (T_m being the melting temperature). The $\{211\}_1/\{211\}_2$ or (010) _{$\Sigma 3$ CSL} facet has to disappear with increasing temperature. The 82° 9R facet appears instead of the 90° (010) _{$\Sigma 3$ CSL} facet. In our samples annealed at 873 K the 90° (110) _{$\Sigma 3$ CSL} facet appears at an angle of 55° to the symmetric twin facets (100) _{$\Sigma 3$ CSL}. To the best of our knowledge, the (110) _{$\Sigma 3$ CSL} facets were never observed before. Therefore, the GB phase transition seems to occur between 0.64 and $0.79 T_m$. In Fig. 1 the phase diagram for $\Sigma 3$ GBs is presented in coordinates "temperature T/T_m – inclination angle θ ". Such phase diagrams are commonly used for the description of phase transitions on the free surfaces of crystals [2–4]. Some minor (210) _{$\Sigma 3$ CSL} and (130) _{$\Sigma 3$ CSL} facets are also present in the samples at 1293 and 1073 K. The length of these facets is only about few per cent of overall length of $\Sigma 3$ GBs. To the best of our knowledge, such $\Sigma 3$ facets in Cu were also never reported in the literature. In Fig. 2 the Wulff-Herring plot is shown for the $\Sigma 3$ GBs at 1293 K constructed using the σ_{GB}/σ_{sur} ratios measured with the aid of AFM. The very low energy of coherent (100) _{$\Sigma 3$ CSL} facets

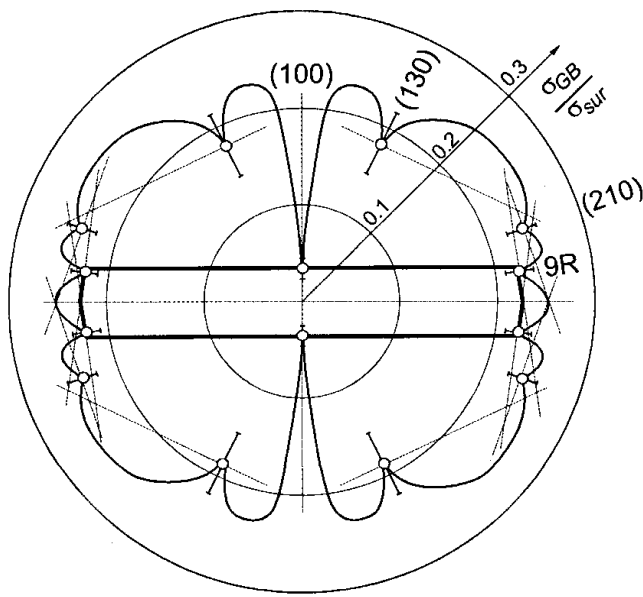

Fig. 2 Wulff-Herring plot for the Σ_3 tilt [110] GBs in Cu at 1293 K obtained with full approximation of the groove profiles. Open circles represent the GB energy (σ_{GB}) for various facets measured with the aid of an AFM. Curved portion is hypothetical. The rings mark the values $(\sigma_{GB} / \sigma_{sur}) = 0.1, 0.2$ and 0.3

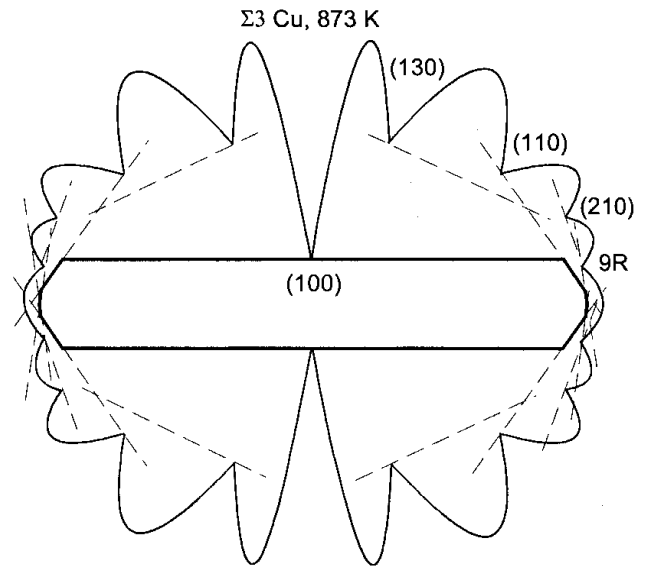

Fig. 3 Schematic Wulff-Herring plot for the Σ_3 tilt [110] GBs in Cu at 873 K. Scheme is constructed using the microscopy data on presence of various GB facets after annealing

determine the platelet-like form of twins in Cu. The metastable nature of the minor $(210)_{\Sigma_3\text{CSL}}$ and $(130)_{\Sigma_3\text{CSL}}$ facets is clearly seen. The presence of the flat $(210)_{\Sigma_3\text{CSL}}$ and $(130)_{\Sigma_3\text{CSL}}$ facets in the sample reveal the existence of the energetic minima on the Wulff-Herring plot. However, it follows from Fig. 2, that these minima are not deep enough to allow the corresponding facets to be stable. In Fig. 3 the scheme of the Wulff-Herring plot is shown for 873 K. A deep energetic minimum exists at the $(110)_{\Sigma_3\text{CSL}}$ inclination and the $(110)_{\Sigma_3\text{CSL}}$ facet appears in the equilibrium shape.

Table 2. The presence of different Σ_9 facets at different temperatures in Cu. Corresponding inclination angles θ and density of coincidence sites S/S_{min} for various CSL planes are also given.

Dissociated facets are marked as *Diss.*

Facet	(110)	(-110)	(100)	(010)	(310)	(-130)	(210)	(510)	(-120)	Referen.
θ , deg	0	71	126	35	152	131	162	142	55	
S/S_{min}	1	1	1.16	1.63	1.98	2.52	2.83	3.00	3.464	[8]
T/T_m										
0.95	Diss.	+							+	This work
0.79	Diss.	+	+	+					+	"-
0.64	Diss.	+	+	+		+			Diss.	"-
0.68	Diss.		+	+	+	+	+	+	+	[8]
0.64	+			+				+		[16]
0	Diss.		+	+	+				+	[9]

In Table. 2 the data are collected on the $\Sigma 9$ facets present in our samples after annealing at 1293, 1073 and 873 K together with the data available in the literature. In Fig. 4 the corresponding phase diagram for $\Sigma 9$ GBs is presented in co-ordinates "temperature T/T_m – inclination angle θ ". As mentioned above, the $(110)_{\Sigma 9\text{CSL}}$ facet is unstable against the dissociation into two $\Sigma 3$ GBs. Therefore, the point with doubled $(100)_{\Sigma 3\text{CSL}}$ energy appears at the $\Sigma 9$ Wulff-Herring plot instead of the energy of the $(110)_{\Sigma 9\text{CSL}}$ facet (Fig. 4). At 1293 K only two facets are present in the sample, namely $(-1,1,0)_{\Sigma 9\text{CSL}}$ and $(-1,2,0)_{\Sigma 9\text{CSL}}$. This fact is reflected by the shape of the Wulff-Herring plot (Fig. 5). At lower temperatures additional facets appear (see Table. 2 and Fig. 4) like $(100)_{\Sigma 9\text{CSL}}$, $(010)_{\Sigma 9\text{CSL}}$ and $(-1,2,0)_{\Sigma 9\text{CSL}}$. At 873 K the $(-1,3,0)_{\Sigma 9\text{CSL}}$ facet appears instead of the $(-1,2,0)_{\Sigma 9\text{CSL}}$ facet.

The possible faceting-defaceting and roughening GB phase transitions were recently discussed [1]. The first direct and deliberate observations of the reversible defaceting transition were made by Hsieh and Balluffi for asymmetric tilt GBs in Al and Au [25]. Westmacott and Dahmen observed that a small Al grain embedded in another Al grain had a polyhedral shape at low temperatures [26]. At high temperature the flat symmetric GB segments became rounded indicating a roughening transition. In our observations the $(100)_{\Sigma 3\text{CSL}}$ and $9R$ facets always have sharp edges at their intersections. In contrast, the intersections of minor $(210)_{\Sigma 3\text{CSL}}$ and $(130)_{\Sigma 3\text{CSL}}$ facets with $9R$ facets are always rounded. The intersections of all $\Sigma 9$ facets are clearly rounded. Generally, all facet intersections become less and less rounded with decreasing temperature. This can be the indication of a roughening-faceting phase transition. These transitions were predicted originally by Burton et al. for singular free surfaces [27]. The planar surface becomes curved with increasing temperature when the thermal energy becomes comparable with depth of energetic minimum for the planar surface [28]. In our case the GB facets positioned in less densely packed CSL planes (e.g. with

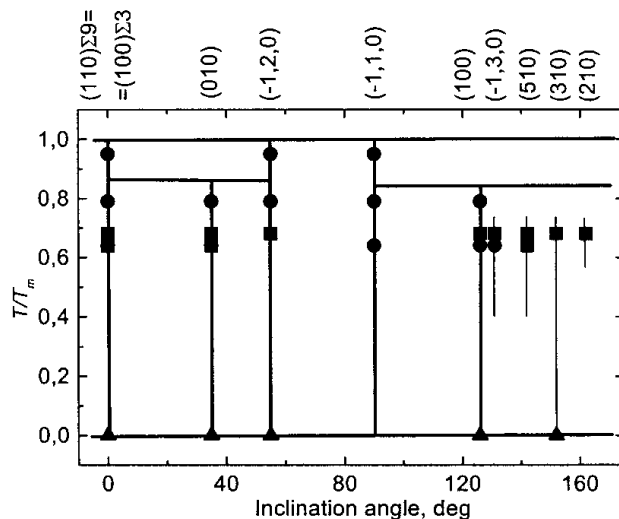

Fig. 4 Phase diagram for the various $\Sigma 9$ facets. The inclinations of $\Sigma 9$ CSL planes are shown at the top of the diagram. Due to the $\Sigma 9 \rightarrow \Sigma 3 + \Sigma 3$ dissociation, the data for $(100)_{\Sigma 3\text{CSL}}$ facet are shown instead of $(110)_{\Sigma 9\text{CSL}}$ facet. Circles denote the facets experimentally observed in this work at $0.95 T_m$ (1293 K), $0.79 T_m$ (1073 K) and $0.64 T_m$ (873 K). Squares denote the facets experimentally observed at $0.68 T_m$ [8] and at $0.64 T_m$ [16]. Triangles denote the energetic minima obtained using computer modelling [9]. Thick lines denote the temperature

ranges of the stability for the major GB facets obtained in this work. Thin lines denote the (1) minor facet $(-1,3,0)_{\text{CSL}}$ and observed in this work and (2) the range of existence for the $(510)_{\text{CSL}}$, $(310)_{\text{CSL}}$ and $(210)_{\text{CSL}}$ facets based on the published observations of other authors [8,16]. Horizontal lines denote the upper limits of stability for $(010)_{\text{CSL}}$ and $(100)_{\text{CSL}}$ facets.

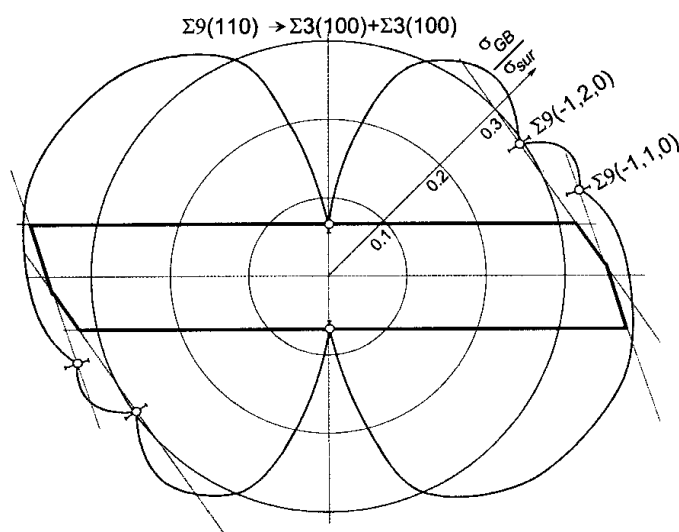

Fig. 5 Wulff-Herring plot for the $\Sigma 9$ tilt [110] GBs in Cu at 1293 K obtained with full approximation of the groove profiles. Due to the $\Sigma 9 \rightarrow \Sigma 3 + \Sigma 3$ dissociation, the value for two (100) $_{\Sigma 3}$ CSL facets is shown instead of (010) $_{\Sigma 9}$ CSL facet. Open circles represent the GB energy σ_{GB} for various facets measured with the aid of AFM. The rings mark the values $(\sigma_{GB} / \sigma_{sur}) = 0.1, 0.2$ and 0.3

shallower energetic minima) become planar with decreasing temperature. The GB roughening seems to be a reasonable explanation for this phenomenon. The change of the shape of intersections of the GB facets and their energy in dependence on the temperature has to be carefully studied in the future.

Acknowledgements

This work was supported by the Russian Foundation of Basic Research (RFBR) under contract 01-02-16473, Deutsche Forschungsgemeinschaft under contracts Gu 258/12-1 and Gu 258/18-1, German Federal Ministry for Education and Research (BMBF) under WTZ-Project RUS 00/209 and. On of us (SAP) expresses his gratitude to the Max-Planck-Institut für Metallforschung for the financial support of his research stay in Stuttgart.

References

1. S.B. Lee, D.Y. Yoon and M.F. Henry: *Acta mater.* Vol. 48 (2000), p. 3071
2. M. Yoon, S.G.J. Mochrie, M.V. Tate, S.M. Gruner and E.F. Eikenberry: *Surf. Sci.* Vol. 411 (1998), p. 70
3. G.M. Watson, D. Gibbs, S. Song, A.R. Sandy, S.G.J. Mochrie and D.M. Zener: *Phys. Rev. B* Vol. B52 (1995), p. 12329
4. S. Song and S.G.J. Mochrie: *Phys. Rev. B* Vol. B51 (1995), p. 10068
5. B.B. Straumal and L.S. Shvindlerman: *Acta metall.* Vol. 33 (1985), p. 1735
6. E.L. Maksimova, L.S. Shvindlerman and B.B. Straumal: *Acta metall.* Vol. 36 (1988), p. 1573
7. A.A. Zisman and V.V. Rybin, *Poverkhnost'*: No. 7 (1982), p. 87 (in Russian)
8. G.D. Sukhomlin and A.V. Andreeva: *phys. stat. sol. (a)* Vol. 78 (1983), p. 333
9. K.L. Merkle and D. Wolf: *Phil. Mag. A* Vol. A65 (1992), p. 523
10. U. Wolf, F. Ernst, T. Muschik, M.W. Finnis and H.F. Fischmeister: *Phil. Mag. A* Vol. A66 (1992), p. 991
11. T. Muschik, W. Laub, M.W. Finnis and W. Gust: *Z. Metallk.* Vol. A84 (1993), p. 596
12. T. Muschik, W. Laub, U. Wolf, M.W. Finnis and W. Gust: *Acta metall. mater.* Vol. A41 (1993), p. 2163
13. W. Laub, A. Oswald, T. Muschik, W. Gust and R.A. Fournelle: in *Solid-Solid Phase Transformations*, ed. by W.C. Johnson et al. (The Minerals, Metals & Materials Society, Warrendale, PA 1994), p. 1115.

14. A. Oswald, W. Laub, W. Gust and R.A. Fournelle: in *Solid–Solid Phase Transformations*, ed. by W.C. Johnson et al. (The Minerals, Metals & Materials Society, Warrendale, PA 1994), p. 1121.
15. F. Ernst, M.W. Finnis, A. Koch, C. Schmidt, B. Straumal and W. Gust: *Z. Metallk.* Vol. 87 (1996), p. 911
16. C.T. Forwood and L.M. Clarebrough: *Acta metall.* Vol. 32 (1984), p. 757
17. L.M. Clarebrough and C.T. Forwood: *phys. stat. sol. (a)* Vol. 60 (1980), p. 51
18. J.M. Pénisson, U. Dahmen and M.J. Mills: *Phil. Mag. Lett.* Vol. 64 (1991), p. 277
19. P.J. Goodhew, T.Y. Tan and R.W. Balluffi: *Acta metall.* Vol. 26 (1978), p. 557
20. F.D. Tichelaar and F.W. Schapink: *J. Phys. Paris* Vol. 49 (1988), p. 293
21. A. Bourret and J. J. Bacmann: *Inst. Phys. Conf. Series* Vol. 78 (1985), p. 337
22. A. Barg, E. Rabkin and W. Gust: : *Acta metall. mater.* Vol. 43 (1995), p. 4067
23. F. Ernst, M.W. Finnis, D. Hoffmann, T. Muschik, U. Schönberger and U. Wolf: *Phys. Rev. Lett.* Vol. 69 (1992), p. 620
24. D. Hofmann and M.W. Finnis: *Acta metall. mater.* Vol. 42 (1994), p. 3555
25. T.E. Hsieh and R.W. Balluffi: : *Acta metall.* Vol. 37 (1989), p. 2133
26. K.H. Wetmacott and U. Dahmen: in *Interface: Structure and Properties*, ed. by S. Ranganathan, C.S. Pande, B.B. Rath and D.A. Smith (Trans Tech Publications, Uetikon-Zuerich 1993), p. 133.
27. W.K. Burton, N. Cabrera and F.C. Frank: *Philos. Trans. A* Vol. A243 (1951), p. 299
28. C. Jayaprakash, W.F. Saam and S. Teitel: *Phys. Rev. Lett.* Vol. A50 (1983), p. 2017